

## Galvanic (Voltaic) Cells

1988

An electrochemical cell consists of a tin electrode in an acidic solution of 1.00 molar  $\text{Sn}^{2+}$  connected by a salt bridge to a second compartment with a silver electrode in an acidic solution of 1.00 molar  $\text{Ag}^+$ .

- Write the equation for the half-cell reaction occurring at each electrode. Indicate which half-reaction occurs at the anode.
- Write the balanced chemical equation for the overall spontaneous cell reaction that occurs when the circuit is complete. Calculate the standard voltage,  $E^\circ$ , for this cell reaction.
- Calculate the equilibrium constant for this cell reaction at 298 K.
- A cell similar to the one described above is constructed with solutions that have initial concentrations of 1.00 molar  $\text{Sn}^{2+}$  and 0.0200 molar  $\text{Ag}^+$ . Calculate the initial voltage,  $E^\circ$ , of this cell.

1993

A galvanic cell is constructed using a chromium electrode in a 1.00-molar solution of  $\text{Cr}(\text{NO}_3)_3$  and a copper electrode in a 1.00-molar solution of  $\text{Cu}(\text{NO}_3)_2$ . Both solutions are at 25°C.

- Write a balanced net ionic equation for the spontaneous reaction that occurs as the cell operates. Identify the oxidizing agent and the reducing agent.
- A partial diagram of the cell is shown below.

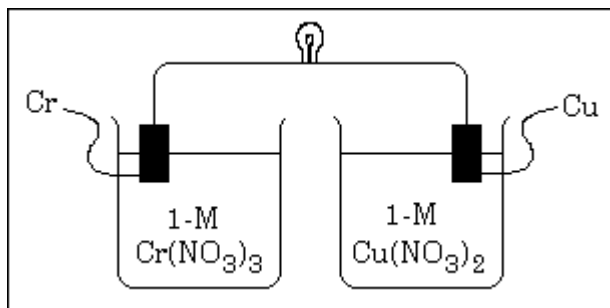

- Which metal is the cathode?
  - What additional component is necessary to make the cell operate?
  - What function does the component in (ii) serve?
- (c) How does the potential of this cell change if the concentration of  $\text{Cr}(\text{NO}_3)_3$  is changed to 3.00-molar at 25°C? Explain.

1996

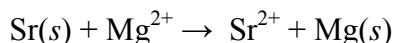

Consider the reaction represented above that occurs at 25°C. All reactants and products are in their standard states. The value of the equilibrium constant,  $K_{\text{eq}}$ , for the reaction is  $4.2 \times 10^{17}$  at 25°C.

- (a) Predict the sign of the standard cell potential,  $E^\circ$ , for a cell based on the reaction. Explain your prediction.
- (b) Identify the oxidizing agent for the spontaneous reaction.
- (c) If the reaction were carried out at 60°C instead of 25°C, how would the cell potential change? Justify your answer.
- (d) How would the cell potential change if the reaction were carried out at 25°C with a 1.0-molar solution of  $\text{Mg}(\text{NO}_3)_2$  and a 0.10-molar solution of  $\text{Sr}(\text{NO}_3)_2$ ? Explain.
- (e) When the cell reaction in (d) reaches equilibrium, what is the cell potential?

1998

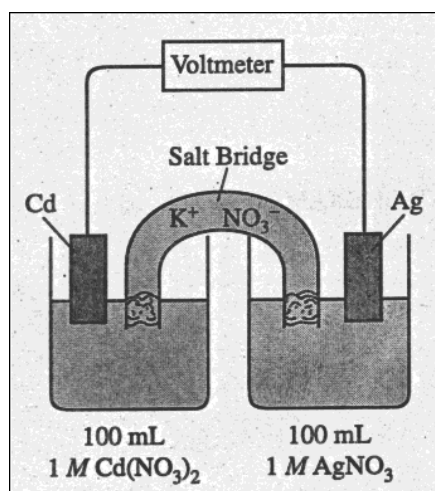

Answer the following questions regarding the electrochemical cell shown above.

- (a) Write the balanced net-ionic equation for the spontaneous reaction that occurs as the cell operates, and determine the cell voltage.
- (b) In which direction do anions flow in the salt bridge as the cell operates? Justify your answer.
- (c) If 10.0 mL of 3.0-molar  $\text{AgNO}_3$  solution is added to the half-cell on the right, what will happen to the cell voltage? Explain.
- (d) If 1.0 grams of solid  $\text{NaCl}$  is added to each half-cell, what will happen to the cell voltage? Explain.
- (e) If 20.0 mL of distilled water is added to both half-cells, the cell voltage decreases. Explain.

2001

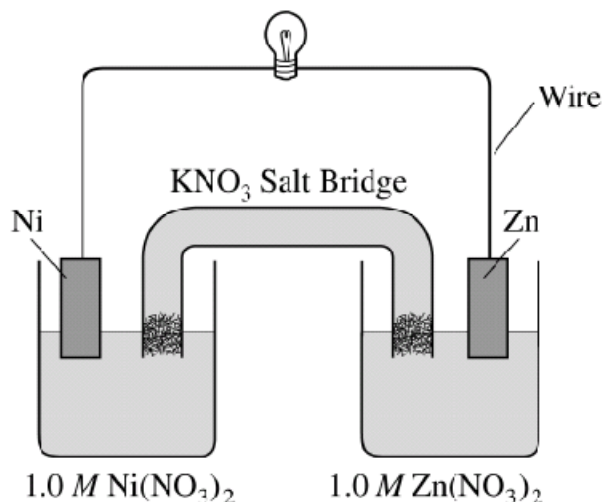

Answer the following questions that refer to the galvanic cell shown in the diagram above.

- Identify the anode of the cell and write the half-reaction that occurs there.
- Write the net ionic equation for the overall reaction that occurs as the cell operates and calculate the value of the standard cell potential,  $E^\circ_{\text{cell}}$ .
- Indicate how the value of  $E_{\text{cell}}$  would be affected if the concentration of  $\text{Ni}(\text{NO}_3)_2(\text{aq})$  was changed from  $1.0\text{ M}$  to  $0.10\text{ M}$  and the concentration of  $\text{Zn}(\text{NO}_3)_2(\text{aq})$  remained at  $1.0\text{ M}$ . Justify your answer.
- Specify whether the value of  $K_{\text{eq}}$  for the cell reaction is less than 1, greater than 1, or equal to 1. Justify your answer.

2002B

The diagram below shows the experimental setup for a typical electrochemical cell that contains two standard half-cells. The cell operates according to the reaction represented by the following equation.

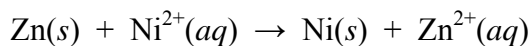

(a) Identify M and  $\text{M}^{2+}$  in the diagram and specify the initial concentration for  $\text{M}^{2+}$  in solution.

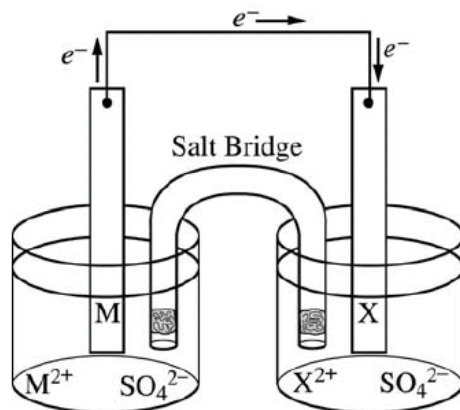

- (b) Indicate which of the metal electrodes is the cathode. Write the balanced equation for the reaction that occurs in the half-cell containing the cathode.
- (c) What would be the effect on the cell voltage if the concentration of  $\text{Zn}^{2+}$  was reduced to  $0.100\text{ M}$  in the half-cell containing the Zn electrode?
- (d) Describe what would happen to the cell voltage if the salt bridge was removed. Explain.

2003B

Answer the following questions about electrochemistry.

- (a) Several different electrochemical cells can be constructed using the materials shown below. Write the balanced net-ionic equation for the reaction that occurs in the cell that would have the greatest positive value of  $E^\circ_{\text{cell}}$ .

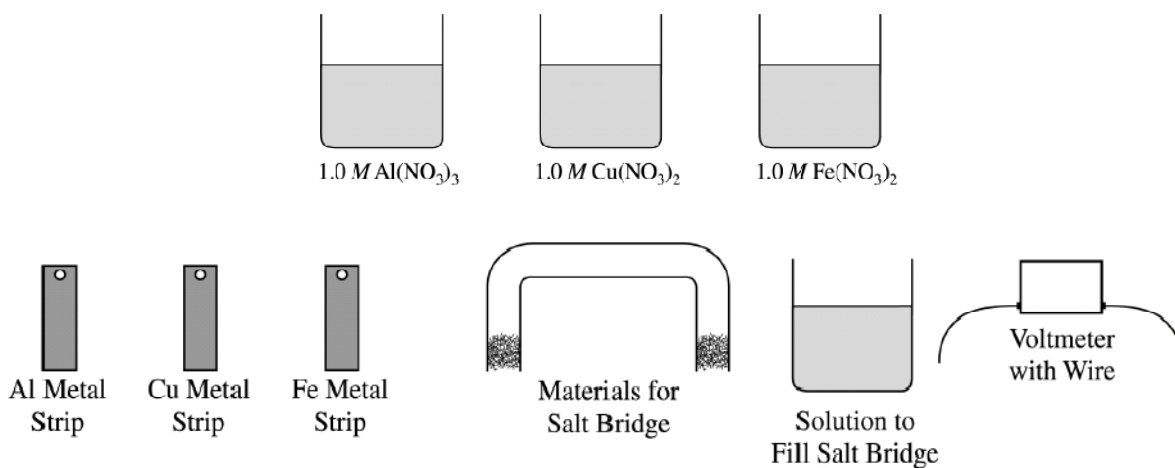

- (b) Calculate the standard cell potential,  $E^\circ_{\text{cell}}$ , for the reaction written in part (a).
- (c) A cell is constructed based on the reaction in part (a) above. Label the metal used for the anode on the cell shown in the figure below.

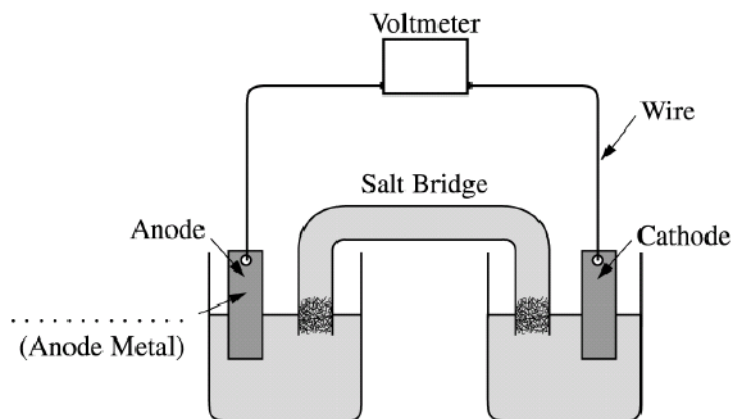

2004B

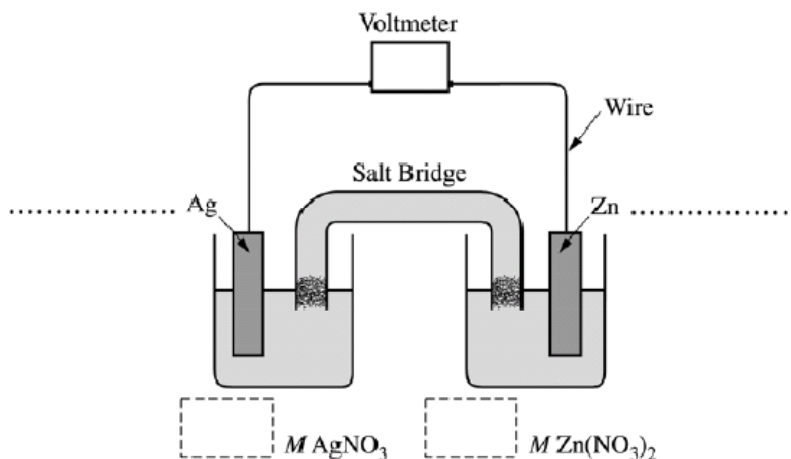

The following questions refer to the electrochemical cell shown in the diagram above.

- Write a balanced net ionic equation for the spontaneous reaction that takes place in the cell.
- Calculate the standard cell potential,  $E^\circ$ , for the reaction in part (a).
- In the diagram above,
  - label the anode and the cathode on the dotted lines provided, and
  - indicate, in the boxes below the half-cells, the concentration of  $\text{AgNO}_3$  and the concentration of  $\text{Zn}(\text{NO}_3)_2$  that are needed to generate  $E^\circ$ .
- How will the cell potential be affected if KI is added to the silver half-cell? Justify your answer.

2005

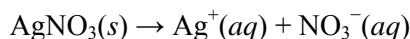

The dissolving of  $\text{AgNO}_3(s)$  in pure water is represented by the equation above.

- Is  $\Delta G$  for the dissolving of  $\text{AgNO}_3(s)$  positive, negative, or zero? Justify your answer.
- Is  $\Delta S$  for the dissolving of  $\text{AgNO}_3(s)$  positive, negative, or zero? Justify your answer.
- The solubility of  $\text{AgNO}_3(s)$  increases with increasing temperature.
  - What is the sign of  $\Delta H$  for the dissolving process? Justify your answer.
  - Is the answer you gave in part (a) consistent with your answers to parts (b) and (c) (i) ? Explain.

The compound  $\text{NaI}$  dissolves in pure water according to the equation  $\text{NaI}(s) \rightarrow \text{Na}^+(aq) + \text{I}^-(aq)$ . Some of the information in the table of standard reduction potentials given below may be useful in answering the questions that follow.

Half-reaction	$E^\circ$ (V)
$\text{O}_2(g) + 4 \text{H}^+ + 4 e^- \rightarrow 2 \text{H}_2\text{O}(l)$	1.23
$\text{I}_2(s) + 2 e^- \rightarrow 2 \text{I}^-$	0.53
$2 \text{H}_2\text{O}(l) + 2 e^- \rightarrow \text{H}_2(g) + 2 \text{OH}^-$	-0.83
$\text{Na}^+ + e^- \rightarrow \text{Na}(s)$	-2.71

- An electric current is applied to a 1.0 M  $\text{NaI}$  solution.
  - Write the balanced oxidation half-reaction for the reaction that takes place.
  - Write the balanced reduction half-reaction for the reaction that takes place.
  - Which reaction takes place at the anode, the oxidation reaction or the reduction reaction?
  - All electrolysis reactions have the same sign for  $\Delta G^\circ$ . Is the sign positive or negative? Justify your answer.

## Electrolytic Cells

1991

Explain each of the following.

- (a) When an aqueous solution of NaCl is electrolyzed,  $\text{Cl}_2(\text{g})$  is produced at the anode, but no  $\text{Na}(\text{s})$  is produced at the cathode.
- (b) The mass of  $\text{Fe}(\text{s})$  produced when 1 faraday is used to reduce a solution of  $\text{FeSO}_4$  is 1.5 times the mass of  $\text{Fe}(\text{s})$  produced when 1 faraday is used to reduce a solution of  $\text{FeCl}_3$ .

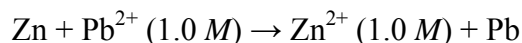

- (c) The cell that utilized the reaction above has a higher potential when  $[\text{Zn}^{2+}]$  is decreased and  $[\text{Pb}^{2+}]$  held constant, but a lower potential when  $[\text{Pb}^{2+}]$  is decreased and  $[\text{Zn}^{2+}]$  is held constant.
- (d) The cell that utilizes the reaction given in (c) has the same cell potential as another cell in which  $[\text{Zn}^{2+}]$  and  $[\text{Pb}^{2+}]$  are each 0.10 M.

1992

An unknown metal M forms a soluble compound,  $\text{M}(\text{NO}_3)_2$ .

- (a) A solution of  $\text{M}(\text{NO}_3)_2$  is electrolyzed. When a constant current of 2.50 amperes is applied for 35.0 minutes, 3.06 grams of the metal M is deposited. Calculate the molar mass of M and identify the metal.
- (b) The metal identified in (a) is used with zinc to construct a galvanic cell, as shown below. Write the net ionic equation for the cell reaction and calculate the cell potential,  $E^\circ$ .

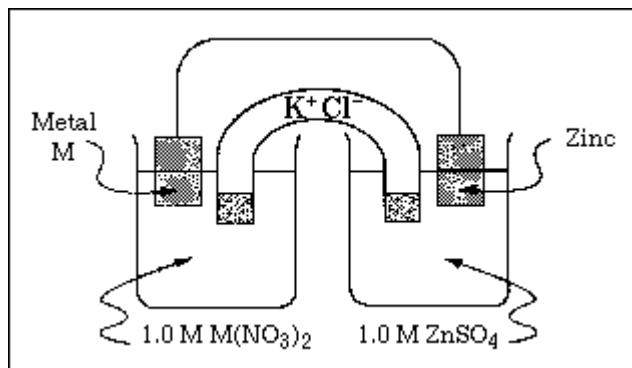

- (c) Calculate the value of the standard free energy change,  $\Delta G^\circ$ , at  $25^\circ\text{C}$  for the reaction in (b).
- (d) Calculate the potential,  $E$ , for the cell shown in (b) if the initial concentration of  $\text{ZnSO}_4$  is 0.10-molar, but the concentration of the  $\text{M}(\text{NO}_3)_2$  solution remains unchanged.



1997

In an electrolytic cell, a current of 0.250 ampere is passed through a solution of a chloride of iron, producing Fe(s) and Cl<sub>2</sub>(g).

- Write the equation for the reaction that occurs at the anode.
- When the cell operates for 2.00 hours, 0.521 gram of iron is deposited at one electrode. Determine the formula of the chloride of iron in the original solution.
- Write the balanced equation for the overall reaction that occurs in the cell.
- How many liters of Cl<sub>2</sub>(g), measured at 25 °C and 750 mmHg, are produced when the cell operates as described in part (b)?
- Calculate the current that would produce chlorine gas at a rate of 3.00 grams per hour.

2000

Answer the following questions that relate to electrochemical reactions.

- Under standard conditions at 25°C, Zn(s) reacts with Co<sup>2+</sup>(aq) to produce Co(s).
  - Write the balanced equation for the oxidation half reaction.
  - Write the balanced net-ionic equation for the overall reaction.
  - Calculate the standard potential,  $E^\circ$ , for the overall reaction at 25°C.

- At 25°C, H<sub>2</sub>O<sub>2</sub> decomposes according to the following equation.

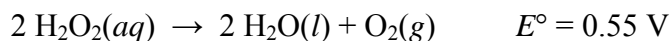

- Determine the value of the standard free energy change,  $\Delta G^\circ$ , for the reaction at 25°C.
- Determine the value of the equilibrium constant,  $K_{eq}$ , for the reaction at 25°C.
- The standard reduction potential,  $E^\circ$ , for the half reaction  $\text{O}_2(g) + 4 \text{H}^+(aq) + 4 e^- \rightarrow 2 \text{H}_2\text{O}(l)$  has a value of 1.23 V. Using this information in addition to the information given above, determine the value of the standard reduction potential,  $E^\circ$ , for the half reaction below.

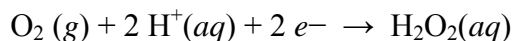

- In an electrolytic cell, Cu(s) is produced by the electrolysis of CuSO<sub>4</sub>(aq). Calculate the maximum mass of Cu(s) that can be deposited by a direct current of 100. amperes passed through 5.00 L of 2.00 M CuSO<sub>4</sub>(aq) for a period of 1.00 hour.

2007B

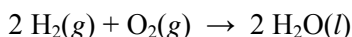

In a hydrogen-oxygen fuel cell, energy is produced by the overall reaction represented above.

- (a) When the fuel cell operates at 25°C and 1.00 atm for 78.0 minutes, 0.0746 mol of  $\text{O}_2(g)$  is consumed. Calculate the volume of  $\text{H}_2(g)$  consumed during the same time period. Express your answer in liters measured at 25°C and 1.00 atm.
- (b) Given that the fuel cell reaction takes place in an acidic medium,
- write the two half reactions that occur as the cell operates,
  - identify the half reaction that takes place at the cathode, and
  - determine the value of the standard potential,  $E$ , of the cell.
- (c) Calculate the charge, in coulombs, that passes through the cell during the 78.0 minutes of operation as described in part (a).